

Automatic Transmission SERVICE GUIDE

**FORDOMATIC
TWO SPEED
OVERHAUL**

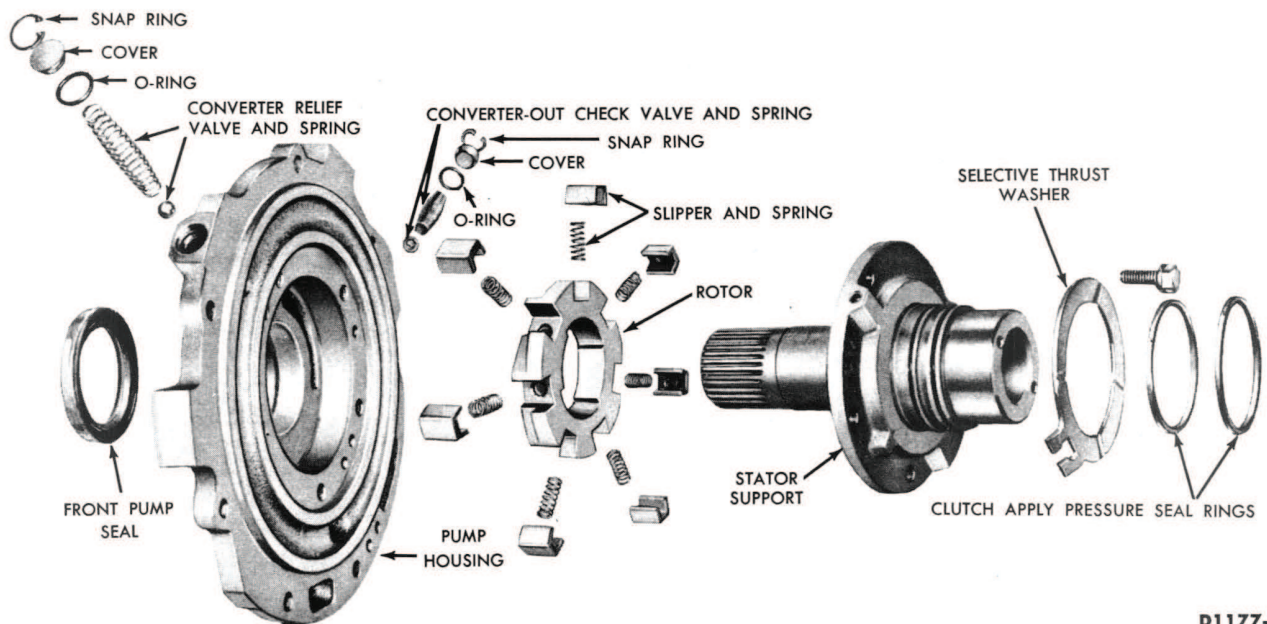
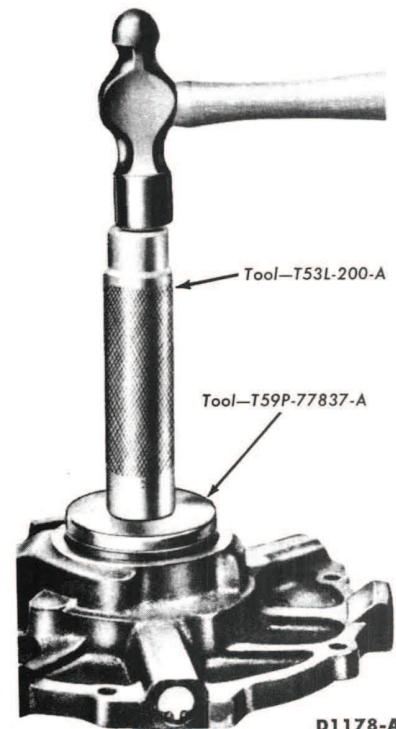

Fig. 7—Front Pump and Stator Support

D1177-A

- ⊗ Remove the rings. Install the rings in their normal operating position in the clutch drum. Check the ring gaps. The ring gaps should measure between .002-.009".
- ⊗ Check the clutch drum front (selective) thrust washer for wear or scores. Check the primary sun gear (turbine) shaft bushing in the stator support shaft.
- ⊗ Remove the rotor and slippers and slipper springs from the front pump housing. Check the pump housing and slippers for excessive wear.
- ⊗ Remove and check the converter pressure relief valve and converter-out check valve. (Fig. 7)
- ⊗ Check the converter pump drive hub bushing in the front pump housing. Check the pump drive hub seal in the pump housing. Use the driving tool if a new seal is to be installed. ⊗



D1178-A

Fig. 8—Front Pump Seal
Installation

Position the rotor and the pump housing with the flat side up.